

Sanlixin Solenoid Valve

SLDF 2/2-way Series UnderWater Solenoid Valve

Description

SLDF series solenoid valve provides on-off control of fluid media on auto-control system. This series is designed for music fountain and dancing fountain.

SLDF series is direct acting solenoid valve which utilize pressure differential to open the valve. They feature diaphragm construction, and together with rapid on-off, stable capability, easy use, and long-life. This valve has strong dirty-tight, can be used long time in river lake sea and kinds of made water areas.



Construction Dimensions Chart

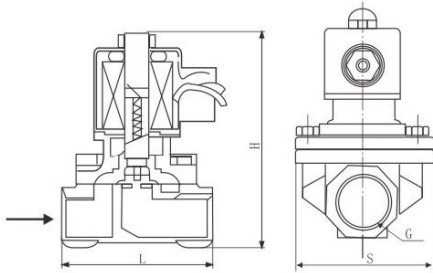

Technical Parameter

1	Ambient Temp.	-10℃~50℃		
2	Operating Pressure	≤ φ 50 0~0.6MPa > φ 65 0.06MPa~0.5MPa		
3	Fluid Media	Water		
4	Fluids Temp.	0℃~60℃		
5	Body Material	Brass、Stainless Steel、Plastic		
5	Voltage	φ 25以上φ 65以上	AC 220V 28VA、DC24V 33W	
		φ 32/40/50	AC 220V 35VA、DC24V 40W	
6	Coil Class	B Class	Degree of protection	IP67
7	Voltage Tolerance	-10%~+10%		
8	Life-span	200000 Times		
9	Response Times	0、2 Sec		
10	Amounting Position	Flow as the arrow		

Specifications

Model code	L (mm)	H(mm)	Pipe Size	Body material	Weight(KG)
SLDF-15	69	117	G1/2"	Brass	1.0
SLDF-20	73	123.5	G3/4"		1.1
SLDF-25	99	134.5	G1"		1.6
SLDF-35	112	172	G1/4"		2.1
SLDF-40	123	172	G1/2"		2.5
SLDF-50	168	209	G2"		4.2
SLDF-15B	69	117	G1/2"	Stainless Steel	0.9
SLDF-20B	73	123.5	G3/4"		1.0
SLDF-25B	99	134.5	G1"		1.5
SLDF-35B	112	172	G1/4"		2.0
SLDF-40B	123	172	G1/2"		2.4
SLDF-50B	168	209	G2"		4.1
SLDF-15S	69	117	G1/2"	Plastic	0.55
SLDF-20S	73	123.5	G3/4"		0.57
SLDF-25S	99	134.5	G1"		0.67

SLDF 2/2-way Series UnderWater Solenoid Valve

Flange structure size

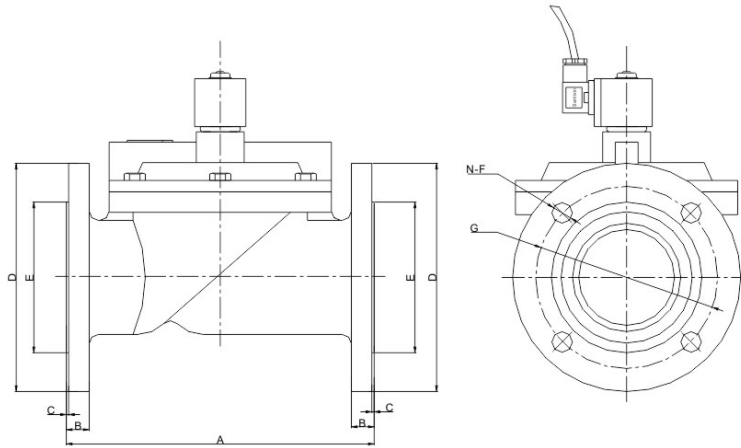

Model code	A	B	C	D	E	F	G	N	Body Material
SLDF-65F	185	20	2	185	118	18	145	4	Cast Iron
SLDF-80F	200	20	2	200	132	18	160	4	
SLDF-100F	220	20	2	220	160	18	180	8	
SLDF-150F	285	24	2	285	212	22	240	8	